

Technisches Datenblatt

FOS-Flachdüse 500mm Länge

Art.Nr: 921-20F , 921-20FNi



FOS
Tribotechnik GmbH

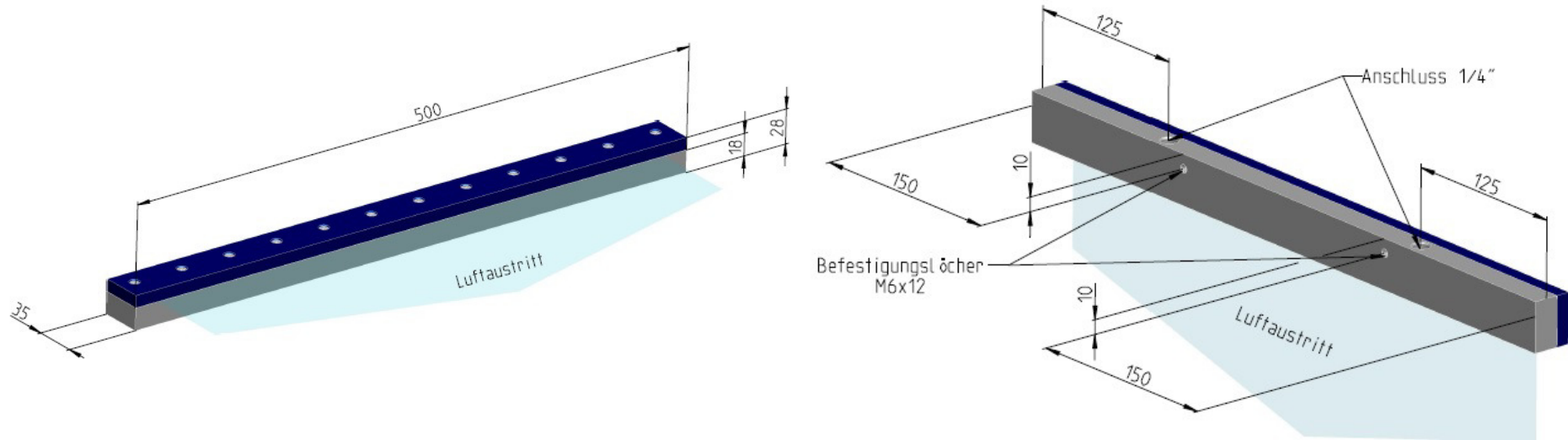

Druck	Druckluftverbrauch	Luftgeschwindigkeit in Entfernung vom Aulass		
		5 cm	15 cm	31 cm
Bar	Liter/Minute	Meter/Sekunde		
2,1	969	64	26	19
4,1	1709	86	50	34
5,5	2202	94	62	43
6,2	2419	99	67	47
6,9	2698	103	72	51

Material 921-20F : Aluminium eloxiert
Material 921-20FNi : Aluminium vernickelt

Gewicht : 1150 Gramm